

HP DesignJet 2500CP  
HP DesignJet 3500CP  
HP DesignJet 2000CP  
HP DesignJet 3000CP  
Printers

## Service Manual

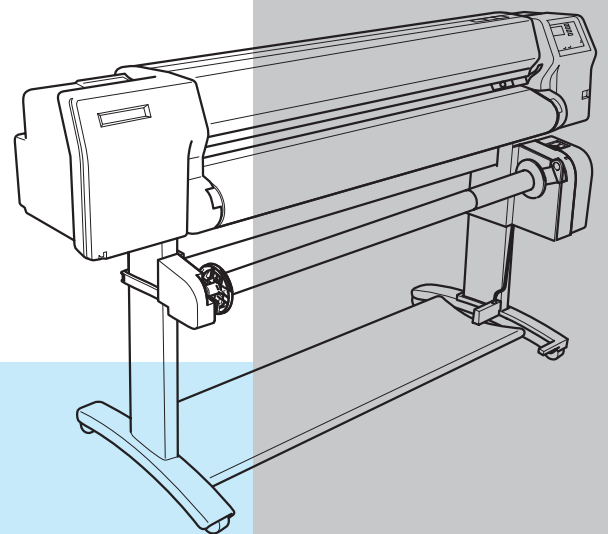

---

**For HP Internal Use Only**

© Copyright Hewlett-Packard Company 1998

This document contains proprietary information that is protected by copyright. All rights are reserved. No part of this document may be photocopied, reproduced, or translated into another language without the prior written consent of Hewlett-Packard Company.

First edition, March 1998  
Second edition, Nov 1998

**Warranty**

The information contained in this document is subject to change without notice.

**Hewlett-Packard makes no warranty of any kind with regard to this material, including, but not limited to, the implied warranties of merchantability and fitness for a particular purpose.**

Hewlett-Packard shall not be liable for errors contained herein or for incidental or consequential damages in connection with the furnishing, performance, or use of this material.

**WARNING**

The procedures described in this manual are to be performed by HP-qualified service personnel only.

**Electrical Shock Hazard**

Serious shock hazard leading to death or injury may result if you do not take the following precautions:

- Ensure that the ac power outlet (mains) has a protective earth (ground) terminal.
- Disconnect the Printer from the power source prior to performing any maintenance.
- Prevent water or other liquids from running onto electrical components or circuits, or through openings in the enclosure.

**Electrostatic Discharge**

Refer to the beginning of Chapter 8 of this manual, for precautions you should take to prevent damage to the Printer circuits from electrostatic discharge.

**Safety Symbols**

General definitions of safety symbols are given immediately after the table of contents.

---

Technical Marketing, Barcelona Division

Hewlett-Packard Española, S.A.  
Avda. Graells, 501  
08190 Sant Cugat del Vallès  
Spain